

# Floor Expansion Joint Profile

## Product Information

<b>Product Model</b>	CPS
<b>Product Type</b>	Floor Expansion Joint Cover/heavy-duty seismic Profile
<b>Material</b>	Aluminum Alloy 6063 T6
<b>Finish</b>	Mill finish

Introducing our CPS Heavy-Duty Seismic Expansion Joint Cover Profile, crafted for areas with substantial traffic loads like private car parking zones and back-of-house spaces with trolley movements. This specially engineered system ensures optimal durability and performance while seamlessly accommodating diverse heavy-duty loads.

## Features and Benefits



**Seismic Movement Capability**  
Designed to accommodate horizontal and vertical movements caused by seismic activity.



**Versatility**  
Accommodates different load types, making it a versatile solution for various commercial and industrial settings.



**Aesthetics**  
Its sleek aluminum design seamlessly integrates with surrounding structures, maintaining a visually appealing environment.



**Easy Installation**  
Quick and hassle-free installation process with clear instructions provided.



**Versatile Weather Endurance**  
Engineered with corrosion-resistant properties, this expansion joint cover is well-suited for indoor and outdoor applications. For outdoor use, a water barrier must be incorporated to ensure optimal performance.

## Maintenance

- > Regularly inspect the expansion joint cover for signs of damage or wear.
- > Clean with mild soap and water as needed to maintain appearance.

Code	Gap width A(mm)	Visible width B(mm)	Installation height C(mm)	Thermal movement (mm)	Seismic movement (mm)	Load Capacity
CPS 25	25	120	25	30mm (+15 -15)	45mm (+30 -15)	Private Vehicles
CPS 35	35	130	25	50mm (+25 -25)	65mm (+40 -25)	Private Vehicles
CPS 50	50	145	25	80mm (+40 -40)	90mm (+50 -40)	Private Vehicles
CPS 75	75	170	25	100mm (+50 -50)	130mm (+65 -65)	Private Vehicles
CPS 100	100	220	25	120mm (+60 -60)	190mm (+100 -90)	Private Vehicles
CPS 150	150	270	25	130mm (+65 -65)	250mm (+110 -140)	Private Vehicles
CPS 200	200	320	25	160mm (+80 -80)	310mm (+120 -190)	Private Vehicles
CPS 250	250	370	25	200mm (+100 -100)	360mm (+120 -240)	Private Vehicles

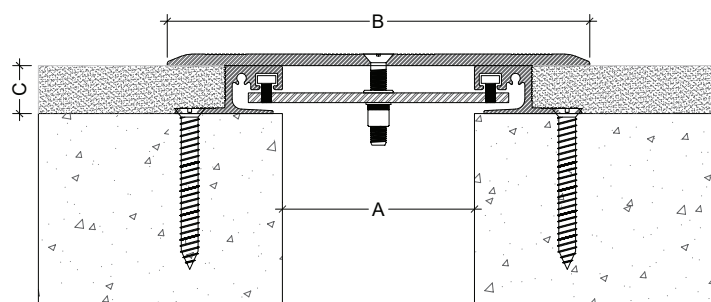

<b>Length</b>	Standard length: 3 meters.
<b>Fire Rating</b>	ASTM E84 Class A.
<b>Installation</b>	Please follow the installation instructions provided in the J-CAP installation guide.